

RFM380F64 SOC Transceiver Module

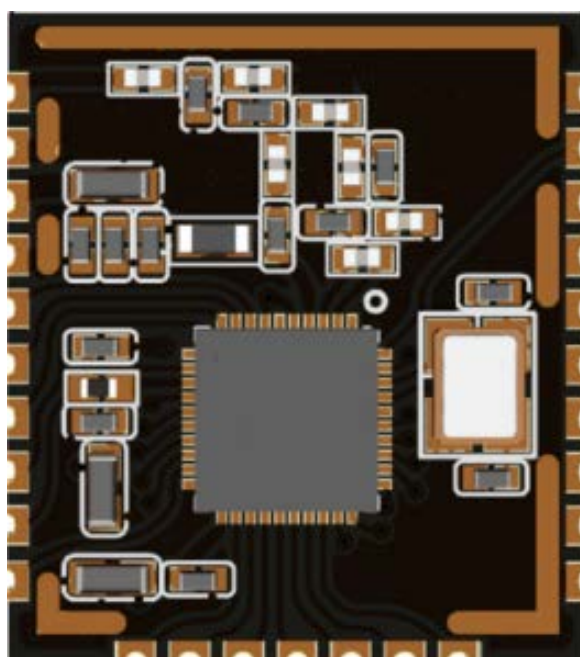

1. General Description

RFM380F64 is a SoC RF transceiver module, which integrates ARM Cortex-M0 32-bit CPU core. It is an ultra-low power RF transceiver with ultra-low power consumption, high sensitivity, long-distance communication, and high cost performance. RFM380F64 has a wealth of peripherals, and supports standard UART, I2C and SPI interfaces. It provides multiple GPIOs and supports internal fast-frequency RC oscillation, internal slow-frequency RC oscillation and 32.768 kHz external crystal oscillator, Also It supports multiple data packet formats and Codec mode, up to 64-byte Tx/Rx FIFO, multiple GPIOs, multiple low-power operation modes and fast startup mechanism, high-precision RSSI, manual fast frequency hopping and multi-channel input 12-bit high-speed ADC. The product can work at three operating frequencies, 434MHz, 868MHz, 915MHz, The data rate range is 0.5-300kbps.

2. Product Features

- ☑ Strong anti-interference ability, suitable for use in complex interference environments
- ☑ Sensitivity: -120dBm @434MHz, 0.6bps, GFSK
- ☑ Working frequency: 434MHz, 868MHz, 915MHz
- ☑ Working voltage: 1.8V-3.6V
- ☑ Transmitting current: 74mA @20dbm @434MHz
- ☑ Receive current: 12mA @434MHz, FSK
- ☑ Deep sleep current: $\leq 2.5\mu\text{A}$
- ☑ Data rate: 0.5-300kbps

3. Application range

- ☑ Smart meter reading
- ☑ Smart home security and building automation
- ☑ Industrial monitoring and control
- ☑ Wireless sensor nodes
- ☑ ISM band data communication

4. Pin Diagram

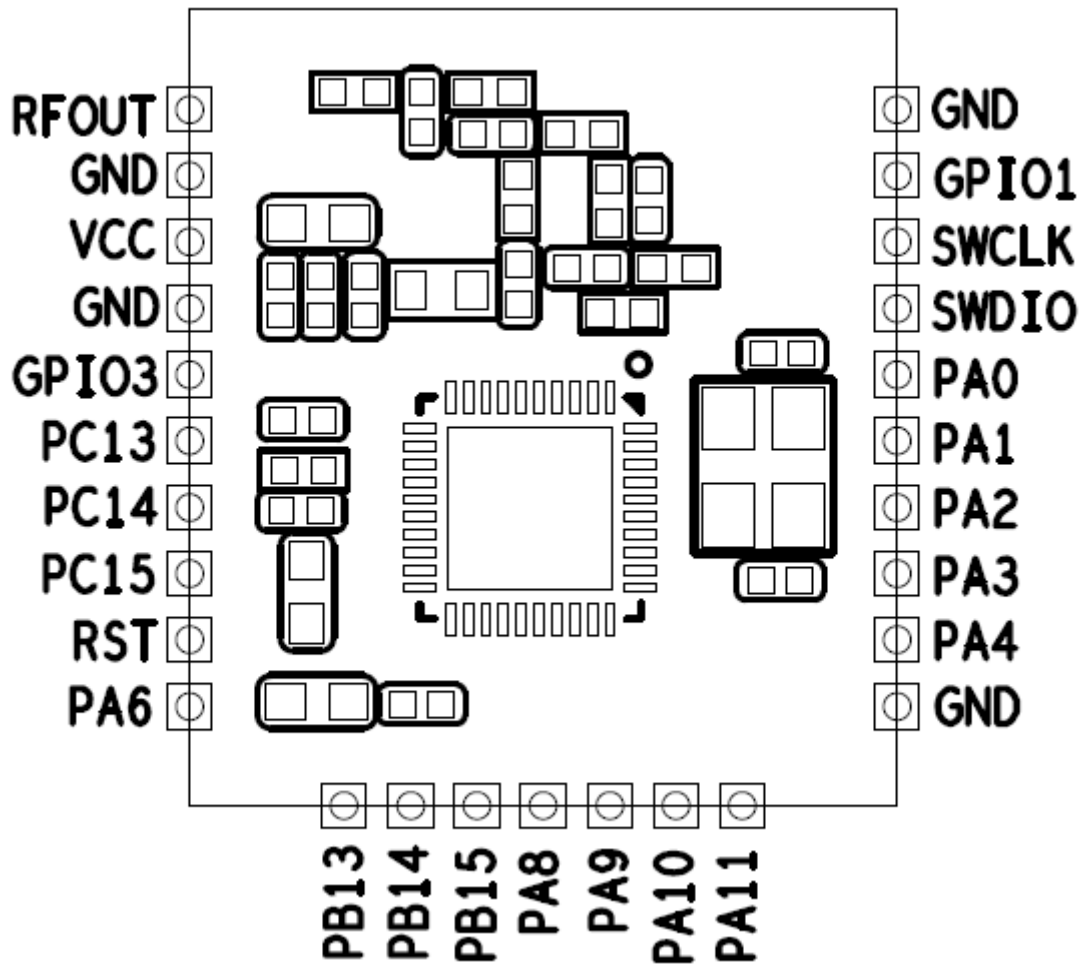

Figure 1. RFM380F64 Pin Diagram

5. Pin definition

Pin	Pin name	Description	Configurable functions
1	RFOUT	RF output	--
2	GND	Ground Power negative	--
3	VCC	1.8V-3.6V Power positive	--
4	GND	Ground Power negative	--
5	GPIO3	RF GPIO3	CLKO, DOUT/DIN, INT2, DCLK (TX/RX)
6	PC13	GPIO	RTC_TAMP1, RTC_TS, RTC_OUT, WKUP1
7	PC14	GPIO	OSC32_IN
8	PC15	GPIO	OSC32_OUT
9	RST	Reset port low level effective	--
10	PA6	GPIO	SPI1_MISO, TIM3_CH1, TIM1_BKIN, TIM8_CH1, EVENT_OUT, LPUART_CTS, LPUART_TX, I2C2_SCL, LPTIM_ETR, BEEPER_OUT, COMP_OUT, ADC_IN6, OPAMP_VOUT
11	PB13	GPIO	SPI1_SCK, I2S_CLK, SPI2_SCK, I2C2_SCL, TIM1_CH1N, LPUART_CTS, TIM8_CH2
12	PB14	GPIO	SPI1_MISO, SPI2_MISO, I2C2_SDA, TIM1_CH2N, TIM8_CH3, LPUART_RTS, OPAMP_VINP
13	PB15	GPIO	SPI1_MOSI, SPI2_MOSI, I2S_SD, TIM1_CH3N, TIM8_CH3N, TIM8_CH4, RTC_REFIN
14	PA8	GPIO	USART1_CK, TIM1_CH1, EVENT_OUT, MCO, SPI2_NSS, TIM8_CH2N
15	PA9	GPIO	USART1_TX, TIM1_CH2, TIM8_BKIN, I2C1_SCL, I2C2_SCL, SPI2_SCK, TIM8_CH1N, LPTIM_OUT, USART2_TX, MCO
16	PA10	GPIO	USART1_RX, TIM1_CH3, TIM8_BKIN, I2C1_SDA, I2C2_SDA, SPI2_MISO, USART2_RX, RTC_REFIN

17	PA11	GPIO	USART1_CTS, TIM1_CH4, EVENT_OUT, I2C2_SCL, SPI2_MOSI, COMP_OUT
18	GND	Ground Power negative	--
19	PA4	GPIO	SPI1_MISO, I2S_MCLK, USART1_CK, USART2_CK, TIM3_CH1, TIM1_CH1, SPI1_NSS, I2S_WS, I2C1_SCL, TIM8_ETR, LPUART_TX, COMP_INM, ADC_IN4, OPAMP_VINP
20	PA3	GPIO	USART1_RX, USART2_RX, TIM8_CH4, TIM1_CH2, SPI1_MISO, I2S_MCLK, LPUART_RX, COMP_INP, ADC_IN3
21	PA2	GPIO	USART1_TX, USART2_TX, TIM8_CH3, SPI1_MOSI, I2S_SD, TIM1_BKIN, WKUP2, ADC_IN2, OPAMP_VINM
22	PA1	GPIO	USART1_RTS, EVENT_OUT, SPI1_NSS, I2S_WS, I2C1_SMBA, LPTIM_IN2, LPUART_TX, TIM8_CH2, TIM3_ETR, COMP_INP, ADC_IN1, OPAMP_VINP
23	PA0	GPIO	USART1_CTS, USART2_CTS, USART2_RX, LPUART_TX, LPUART_RX, SPI1_SCK, I2S_CLK, LPTIM_IN1, TIM8_CH1RTC_TAMP2, WKUP0, COMP_INM, COMP_OUT, ADC_IN0, OPAMP_VINP
24	SWDIO	SW debug data port	PA13, USART1_TX, USART1_RX, USART2_RX, I2C1_SDASPI1_SCK, I2S_CLK
25	SWCLK	SW debug clock port	PA14, USART1_TX, USART2_TX, I2C1_SMBA, SPI1_MISO
26	GPIO1	RF GPIO1	DOUT/DIN, INT1, INT2, DCLK (TX/RX), RF_SWT
27	GND	Ground Power negative	--

Table 1. RFM380F64 Pin definitions

Note: The test point of the module is the SPI interface of the RF circuit, and the pin definition is shown in the figure below.

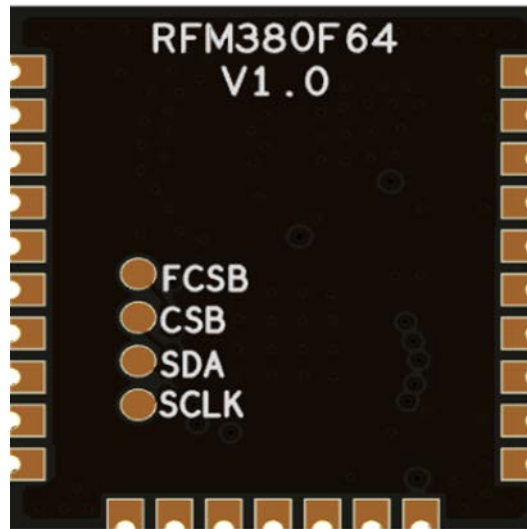

Figure 2. RFM380F64 Test Point Definition

6. Electrical Parameters

Test conditions: Power supply 3.3V, working temperature 25°C

Table 2. Electrical Parameters

Parameter	Symbol	Conditions	Min	Typ	Max	Unit
Working frequency	F _c	RFM380F64-433S2		434		MHz
		RFM380F64-868S2		868		MHz
		RFM380F64-915S2		915		MHz
Modulation	MOD		GFSK			
Receiving sensitivity	SENS	434MHz, DR = 2.0 kbps, F _{DEV} = 10 kHz		-118		dBm
		868MHz, DR = 2.0 kbps, F _{DEV} = 10 kHz		-116		dBm
		915MHz, DR = 2.0 kbps, F _{DEV} = 10 kHz		-115		dBm
Data rate	DR		0.5	2.4	300	Kbps
Receiving band width	BW		50		330	KHz
Working voltage	VDD		1.8	3.3	3.6	V
Receiving current	I _{Rx}	434MHz		12	15	mA
		868MHz		12	15	mA
		915MHz		12	15	mA
Transmitting current	I _{Tx}	434MHz +20dbm		74	85	mA
		868MHz +20dbm		80	90	mA
		915MHz +20dbm		82	90	mA
Sleep current	I _{Sleep}			2.5		uA
mirror frequency rejection	IMR	FRF=433 MHz		35		dBc
		FRF=868 MHz		33		dBc
		FRF=868 MHz		33		dBc
Working temperature	TOP		-40		+85	°C

7. Dimension

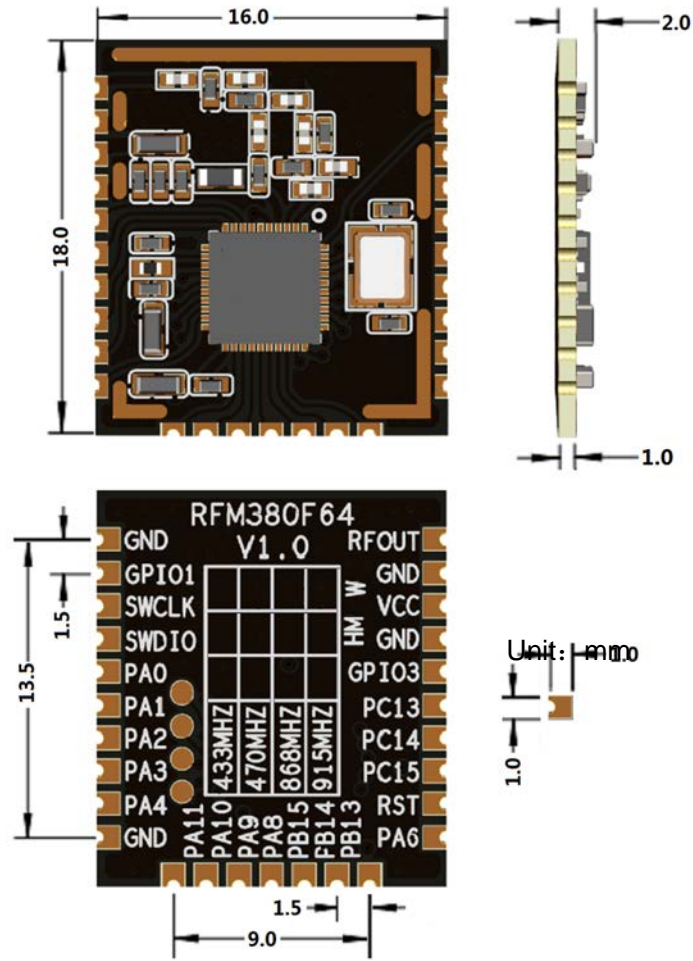

Figure 3. Module dimensions (Unit: mm)

8. Ordering information

Model	Frequency
RFM380F64-433S2	434MHz
RFM380F64-868S2	868MHz
RFM380F64-915S2	915MHz